



## Screw Compressor HK06ZB001 Oil Safety Switch Application Change

Recently, Carlyle Compressor Application Engineering discovered that the HK06ZB001 oil pressure differential safety switch utilized on the Carlyle 06T and 05T screw compressors does not perform as required in some applications. When utilizing refrigerants R-404a or R-507 at saturated condensing temperatures above 80° SCST, in the unlikely event that the oil solenoid feeding the compressor fails closed during compressor operation, the oil pressure differential switch will

not shut down the compressor. Under these circumstances, failure of the oil line solenoid to open will ultimately cause the compressor to fail due to a lack of required lubrication. To successfully protect the compressor, a modification to how this oil protection switch is applied will be required. To insure that the required changes are clear to everyone, we will review the current operation of this switch and then explain the required changes necessary for proper operation in the future.

---

### **Current Connection Points and Operation (Drawing 1)**

- Switch high pressure connection is currently connected to compressor oil inlet pressure access port
- Switch low pressure connection is currently connected to compressor suction pressure access port.
- If compressor oil inlet pressure drops to less than 45 psi above compressor suction pressure, after a delay of 45 seconds the switch will trip and the compressor will shut down. (Problem is that in some cases even with the oil line solenoid closed the compressor oil inlet pressure will remain more than 45 psi above compressor suction pressure.)

### **New Connection Points and Operation (Drawing 2)**

- Switch high pressure connection "labeled Oil" will be connected to compressor discharge pressure access port.
- Switch low pressure connection "labeled LP" will be connected to compressor oil inlet pressure access port.
- If compressor oil inlet pressure drops to more than 45 psi below compressor discharge pressure, after a delay of 45 seconds the switch will trip and the compressor will shut down. (This change will mean that the switch will open on a rise in pressure differential. A minor wiring change within the switch will make this possible.)
- Please refer to the following directions and diagrams for assistance in changing the compressor and switch piping connection points and the switch wiring.

- Upon request, Carlyle Compressor will supply a new compressor discharge pressure access fitting which will allow connection of the oil failure switch high pressure port along with the compressor high pressure cutout switch and reverse rotation switch. (All three must be connected to the compressor discharge pressure access port.)



---

### Suggested Rework Procedure:

1. Note: Only compressors that utilize refrigerants R-404a or R-507 will require this rework. Compressors that utilize refrigerants **R-22 or R-134a are not included and will not need this rework.**
2. Prior to beginning rework, request new compressor discharge pressure access port fittings for all compressors requiring this rework from Carlyle Compressor Sales by calling (800) 532-5036. Be prepared to supply ship to address, contact name and phone number.
3. Shut off the compressor and disconnect all compressor and control circuit power, verify all power is off with a properly functioning volt meter.
4. Isolate the compressor from the system by closing all compressor service valves including the oil line isolation valve.
5. Reclaim / Remove all refrigerant from the compressor.
6. Disconnect pressure lines to oil protection switch.
7. Remove oil protection switch from compressor making sure to label any wiring you may need to remove so that the switch may be reinstalled correctly.
8. Remove oil protection switch from its metal case as shown on drawing #3.
9. Move the internal wire currently connected to terminal #3 on the rear SPDT switch and reinstall on terminal #2 as shown on drawing #4.
10. Reinstall switch in its metal case.
11. Reinstall switch on compressor and re-pipe the switch high "labeled Oil" and low "labeled LP" pressure connections to the new compressor connections as shown on drawing #5 using the new compressor discharge pressure access port fitting supplied by Carlyle Compressor Sales.
12. Evacuate compressor and check for leaks.
13. Label switch with new part # **HK06ZB006** (If switch were to fail in the future this is the replacement part number with the correct internal wiring).
14. Once rework is complete put compressor back into service.

---

*To offset the labor costs involved with retrofitting existing compressors to this new oil failure switch configuration, Carlyle Compressor Sales will reimburse the end user or contractor a maximum of \$50 per compressor to make this change. **Compressor model number, serial number, store name and address along with the date that this work was performed must be submitted to Carlyle Compressor Sales on end user or contractor letterhead via fax at (315) 432-3274 for payment to be issued.** On multiple compressor systems, the risk of catastrophic system failure does not exist due to this problem, therefore, we would suggest that this change be made during scheduled routine system maintenance.*

### Current Oil Protection Switch Position Screw - Oil System

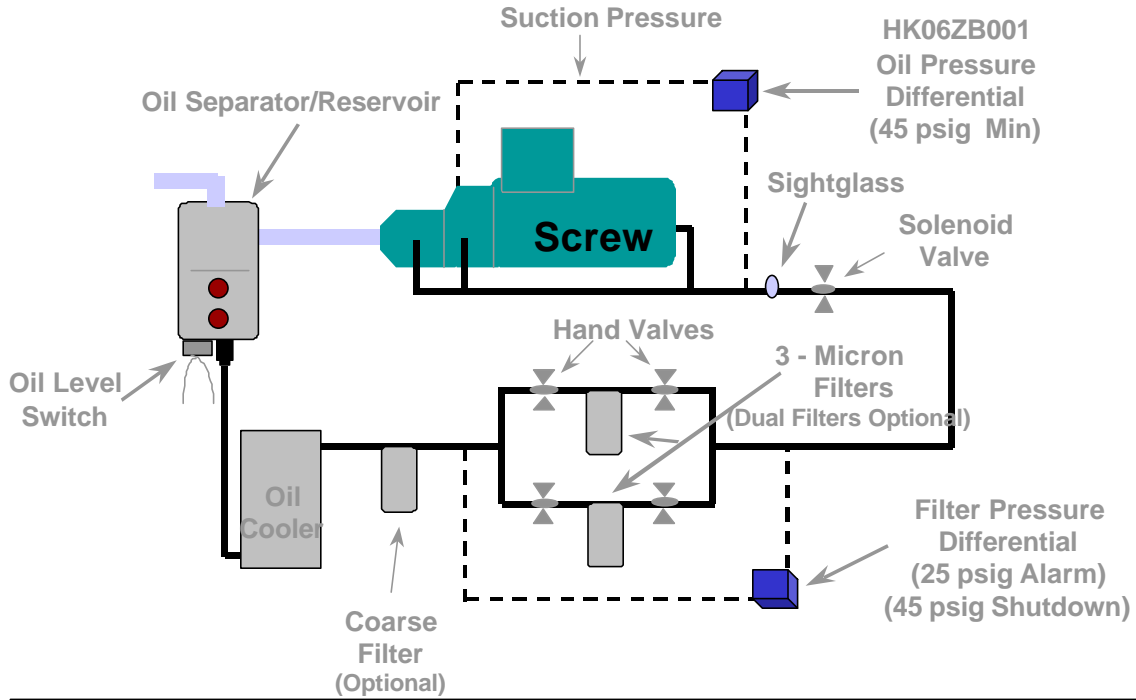

As used today, the oil pressure differential switch sees oil pressure (high side) on the high connection and suction pressure on the low connection. The differential can be as high as 320 psid.

### New Oil Protection Switch Position Screw - Oil System

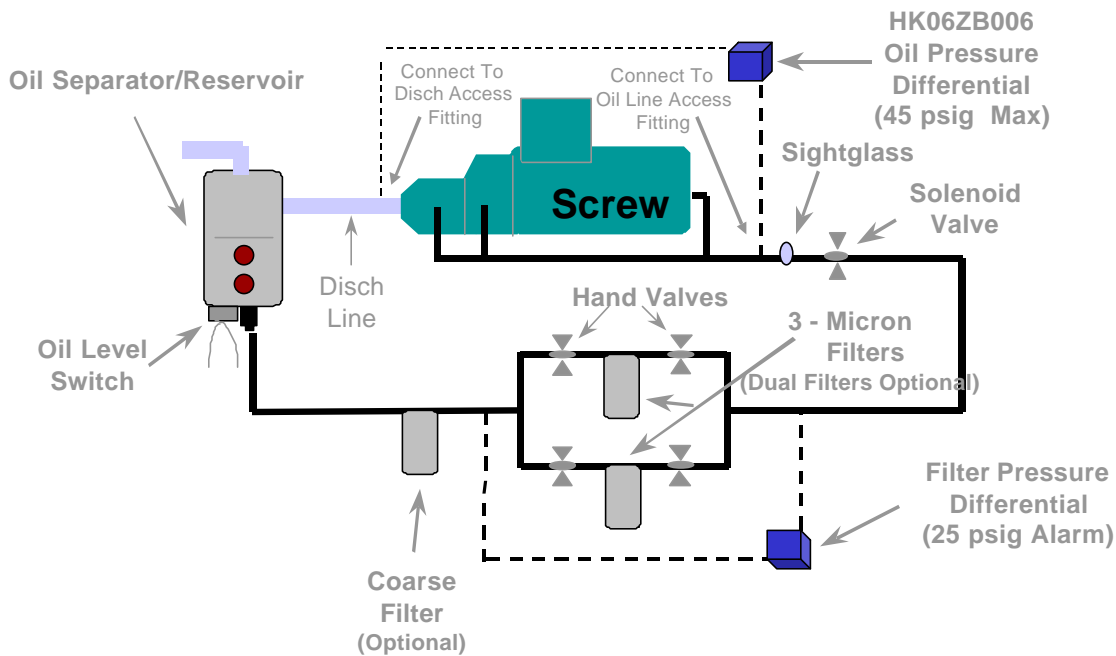

While running the oil pressure differential switch will see high side pressure on both connections  
When the compressor shuts down the switch will see suction pressure on both connections

# Drawing #3



To Disassemble Switch  
First Remove Cover By  
Removing Cover Screw

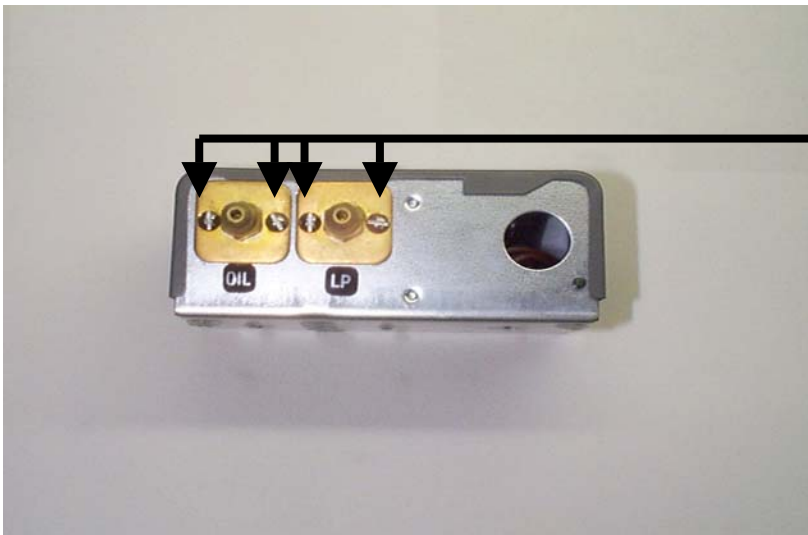

Then Remove 4 Screws  
Which Hold  
Pressure Connections  
To Switch Case

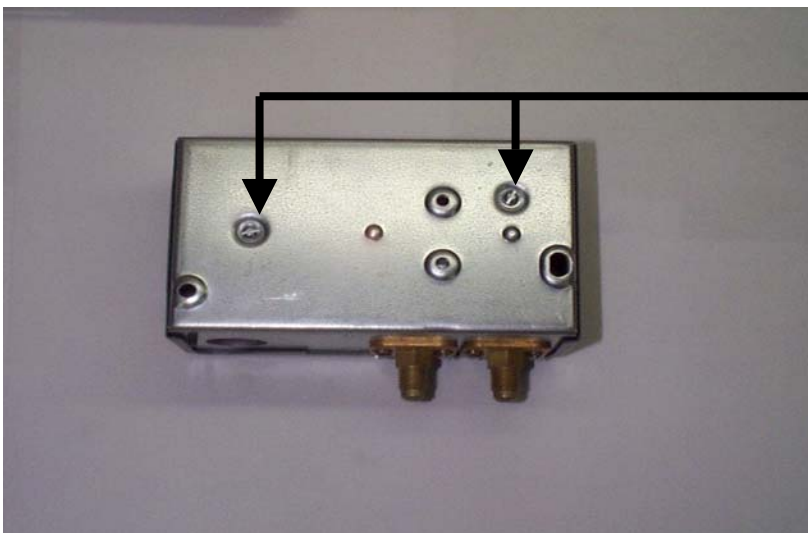

Finally Remove 2 Screws  
From Switch Back To  
Allow Switch To Be  
Removed From Case

# Drawing #4

Once Switch Has Been Removed From Case Move The Wire Currently Connected To Rear Terminal #3, To Rear Terminal #2  
This Will Change The Action Of The Switch

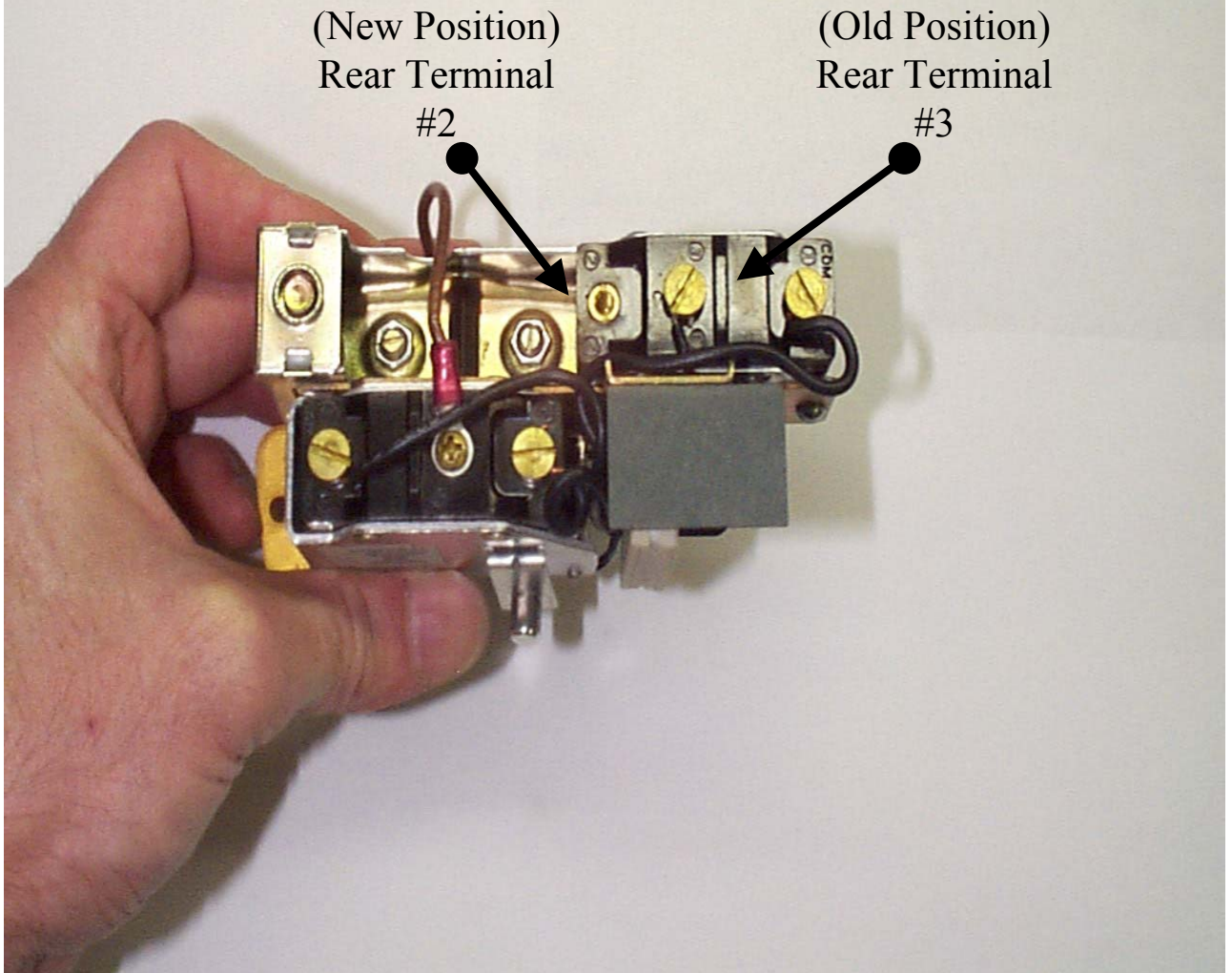

Once Wire Has Been Moved To Terminal #2 Switch May Be Reinstalled Back In Case And Remounted On Compressor Or Rack Frame

Reconnect Switch Pressure Connections  
To Compressor As Shown Below

# Drawing #5

**Switch High  
Pressure Connection  
(Discharge)**

**Switch Low  
Pressure Connection  
(Oil Inlet)**

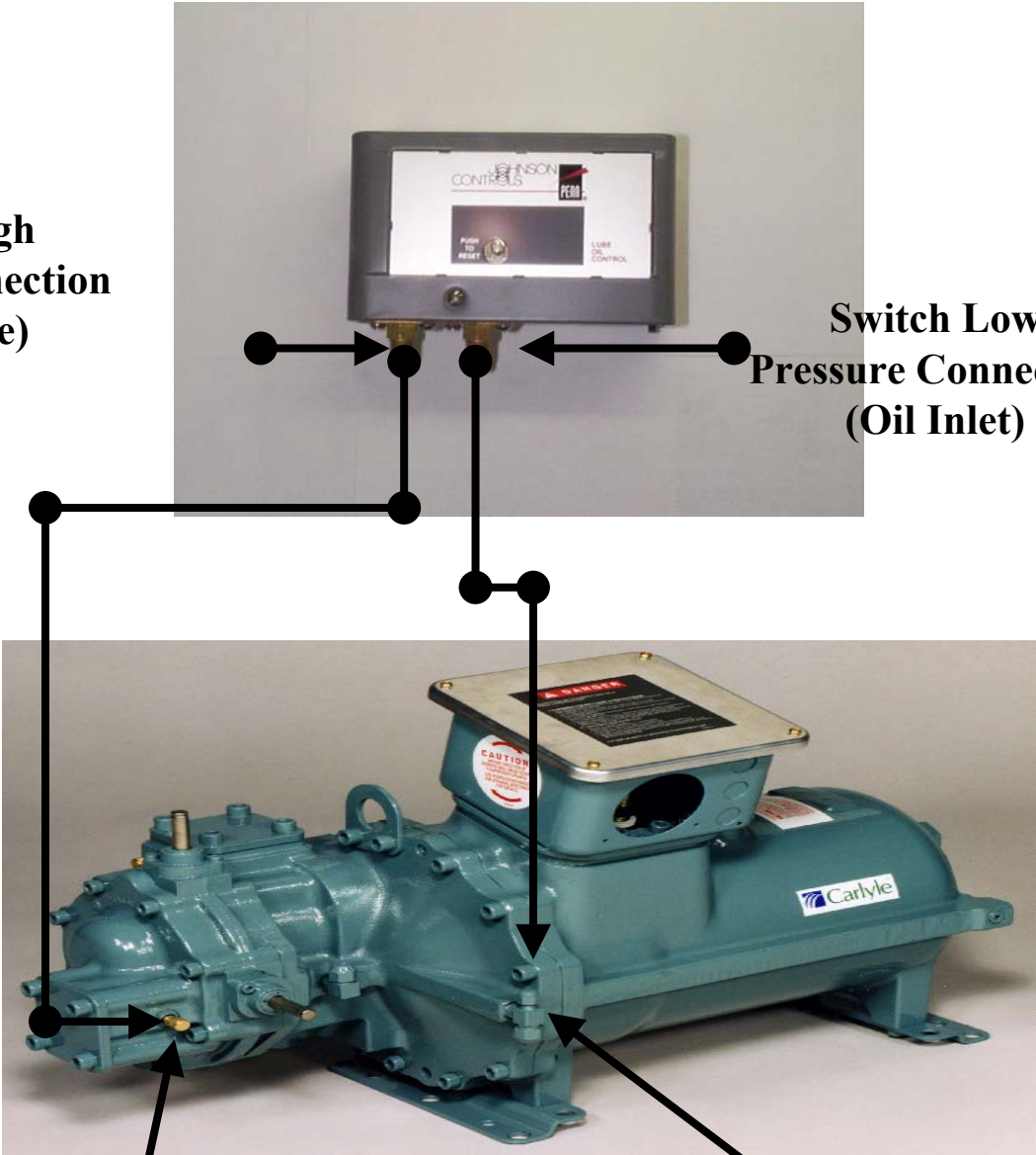

**Compressor Discharge  
Pressure Access Port**  
Replace Single Point  
Access Fitting With  
3 Point Fitting Supplied  
By Carlyle

**Compressor  
Oil Inlet Pressure  
Access Port**